



**DUO 3**

**Rotary Vane Pump**

# Operating Instructions

# Table of contents

<b>1</b>	<b>About this manual</b> .....	<b>3</b>
1.1	Validity .....	3
1.2	Conventions .....	3
<b>2</b>	<b>Safety</b> .....	<b>5</b>
2.1	Safety precautions .....	5
2.2	Protective equipment .....	5
2.3	Proper use .....	6
2.4	Improper use .....	6
<b>3</b>	<b>Transport and storage</b> .....	<b>7</b>
3.1	Transport .....	7
3.2	Storage .....	7
<b>4</b>	<b>Product description</b> .....	<b>8</b>
4.1	Product identification .....	8
4.2	Function .....	9
<b>5</b>	<b>Installation</b> .....	<b>9</b>
5.1	Set-up .....	9
5.2	Filling up the operating fluid .....	10
5.3	Connecting the vacuum side .....	11
5.4	Connecting the exhaust side .....	11
5.5	Connecting to the mains power supply .....	13
<b>6</b>	<b>Operation</b> .....	<b>15</b>
6.1	Before switching on the pump .....	15
6.2	Switching on .....	15
6.3	Pumping condensable vapours .....	15
6.4	Switching off the pump .....	18
<b>7</b>	<b>Maintenance</b> .....	<b>18</b>
7.1	Precautions .....	18
7.2	Changing the operating fluid .....	20
<b>8</b>	<b>Decommissioning</b> .....	<b>22</b>
8.1	Shutting down for longer periods .....	22
8.2	Re-starting .....	22
8.3	Disposal .....	22
<b>9</b>	<b>Malfunctions</b> .....	<b>23</b>
9.1	Rectifying malfunctions .....	23
<b>10</b>	<b>Service</b> .....	<b>25</b>
<b>11</b>	<b>Spare parts</b> .....	<b>26</b>
11.1	Spare parts packages .....	26
<b>12</b>	<b>Accessories</b> .....	<b>29</b>
<b>13</b>	<b>Technical data and dimensions</b> .....	<b>29</b>
13.1	General .....	29
13.2	Technical data .....	30
13.3	Dimensions .....	30
	<b>Declaration of conformity</b> .....	<b>31</b>

# 1 About this manual

## 1.1 Validity

This operating manual is for customers of Pfeiffer Vacuum. It describes the functioning of the designated product and provides the most important information for safe use of the unit. The description follows applicable EU guidelines. All information provided in this operating manual refer to the current state of the product's development. The documentation remains valid as long as the customer does not make any changes to the product.

Up-to-date operating instructions can also be downloaded from [www.pfeiffer-vacuum.com](http://www.pfeiffer-vacuum.com).

### Applicable documents

DUO 3	Operating instructions
Declaration of Conformity	Part of this document
Operating instructions for accessories (order-specifically)	see section "accessories"

\*also available via [www.pfeiffer-vacuum.com](http://www.pfeiffer-vacuum.com)

## 1.2 Conventions

### Safety instructions

The safety instructions in Pfeiffer Vacuum operating instructions are the result of risk evaluations and hazard analyses and are oriented on international certification standards as specified by UL, CSA, ANSI Z-535, SEMI S1, ISO 3864 and DIN 4844. In this document, the following hazard levels and information are considered:

<b>DANGER</b>
<b>Imminent danger</b> Indicates an imminent hazardous situation that will result in death or serious injury.
<b>WARNING</b>
<b>Possibly imminent danger</b> Indicates an imminent hazardous situation that can result in death or serious injury.
<b>CAUTION</b>
<b>Possibly imminent danger</b> Indicates an imminent hazardous situation that can result in minor or moderate injury.
<b>NOTICE</b>
<b>Command or note</b> Command to perform an action or information about properties, the disregarding of which may result in damage to the product.

## Pictograph definitions



Prohibition of an action or activity in connection with a source of danger, the disregarding of which may result in serious accidents



Warning of a displayed source of danger in connection with operation of the unit or equipment



Command to perform an action or task associated with a source of danger, the disregarding of which may result in serious accidents



Important information about the product or this document

## Instructions in the text

→ Work instruction: here you have to do something.

## Abbreviations used

**C version:** Corrosive gas version

## Symbols used

The following symbols are used consistently throughout in all illustrations:

- ⓪ Vacuum flange
- Ⓛ Exhaust flange
- Ⓜ Gas ballast valve
- Ⓝ Power connection

## 2 Safety

### 2.1 Safety precautions



#### Duty to inform

Each person involved in the installation, operation or maintenance of the vacuum pump must read and observe the safety-related parts of these operating instructions.

→ The operator is obligated to make operating personnel aware of dangers originating from the vacuum pump, the pumped medium and the entire system.



#### Installation and operation of accessories

Pfeiffer Vacuum pumps can be equipped with a series of adapted accessories. The installation, operation and maintenance of connected devices are described in detail in the operating instructions of the individual components.

→ For information on order numbers of components, see "Accessories".

→ Use original accessory parts only.

- Do not expose any body parts to the vacuum.
- Observe the safety and accident prevention regulations.
- Check regularly that all safety precautions are being complied with.
- Do not carry out any unauthorised modifications or conversions to the pumps.
- Depending on the operating and ambient conditions, the surface temperature of the pumps may rise above 70 °C. Use suitable finger guards if necessary.
- When returning the pumps to us please note the instructions in the Service section.

### 2.2 Protective equipment

Determined situations concerning the handling of vacuum pumps require wearing of personal protective equipment. The owner, respectively the employer are obligated to provide adequate equipment to any operating persons.



#### DANGER

#### Danger to health by hazardous substances during maintenance or installation

Depending on the process vacuum pumps, components or operating fluids can be contaminated by toxic, reactive or radioactive substances.

→ Wear adequate protective equipment during maintenance and repairs or in case of reinstallation.



#### CAUTION

#### Risk of injury through hot surfaces

Vacuum pumps can become hot during operation.

→ Allow the pump to cool before maintenance and repairs.

→ If necessary wear protective gloves according to directive EN 420.



#### WARNING

#### Increased noise emission!

Increased noise emission can occur within a limited area surrounding the vacuum pump.

→ Provide noise protection or

→ wear hearing protection.

## 2.3 Proper use



### NOTICE

#### CE conformity

The manufacturer's declaration of conformity becomes invalid if the operator modifies the original product or installs additional components.

→ Following installation into a plant and before commissioning, the operator must check the entire system for compliance with the valid EU directives and reassess it accordingly.

- The vacuum pump may only be used to generate a vacuum.
- Installation, operating and maintenance regulations must be complied with.
- Other accessories, than those described in this manual, must not be used without the agreement of Pfeiffer Vacuum.

## 2.4 Improper use

Improper use will cause all claims for liability and warranties to be forfeited. Improper use is defined as usage for purposes deviating from those mentioned above, especially:

- pumping of corrosive gases
- pumping of explosive media
- operation in potentially explosive areas
- pumping of gases containing impurities such as particles, dusts and condensate; note the vapour compatibility levels of the pump
- pumping of substances that tend to sublime
- use of the vacuum pump to generate pressure
- pumping of liquids
- the use of operating fluids not specified by Pfeiffer Vacuum
- connection to pumps or units which are not suitable for this purpose according to their operating instructions
- connection to units which have exposed voltage-carrying parts

## 3 Transport and storage

### 3.1 Transport

#### Transport instructions

- Remove the locking cap from the vacuum and exhaust flange immediately before connecting!
  - Check the cone strainer, paying attention to the O-ring.
- Use only the handle on the top side of the pump to lift the pump.

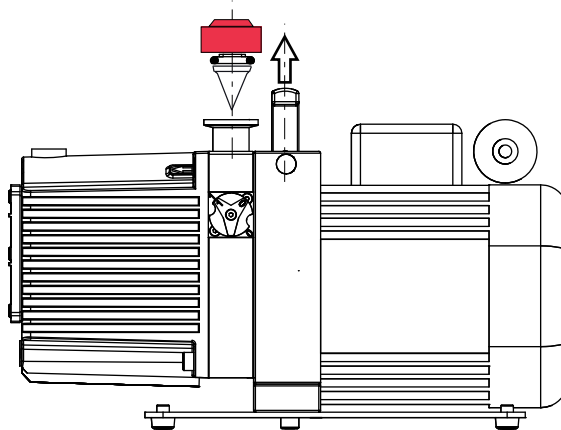

Fig. 1: Transporting the pump

### 3.2 Storage

- Check that all the openings on the pump are securely closed.
- Store the pump in a cool, dry place; preferably at temperatures between  $-10\text{ }^{\circ}\text{C}$  and  $+40\text{ }^{\circ}\text{C}$ .
  - For a longer period of storage, seal the pump in a PE bag with drying agents enclosed.
  - For a period of storage longer than two years, it is recommended to change the operating fluid before using the pump.

## 4 Product description

### 4.1 Product identification

To correctly identify the product when communicating with Pfeiffer Vacuum, always have the information from the rating plate available.

- Pump model and model number
- Type and amount of operating fluid
- Date of manufacture

Please find the voltage range and motor-related data on the separately attached motor rating plate.

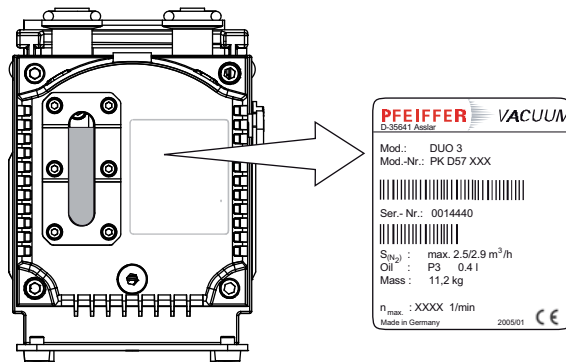

Fig. 2: Product identification on the rating plate

### Scope of delivery

- Pump with motor (mains cable/power switch --> dependent on the motor type)
- Operating fluid P3 (for standard pump)
- Cone strainer and centering ring with O-ring
- Locking cap for vacuum and exhaust flange
- Operating instructions



## 4.2 Function

Vacuum pumps of the DUO series are oil-sealed, two-stage rotary vane vacuum pumps. The vacuum pumps are equipped with a high vacuum safety valve which, when the pump is at a standstill, closes the vacuum chamber vacuum tight and at the same time vents the pump.

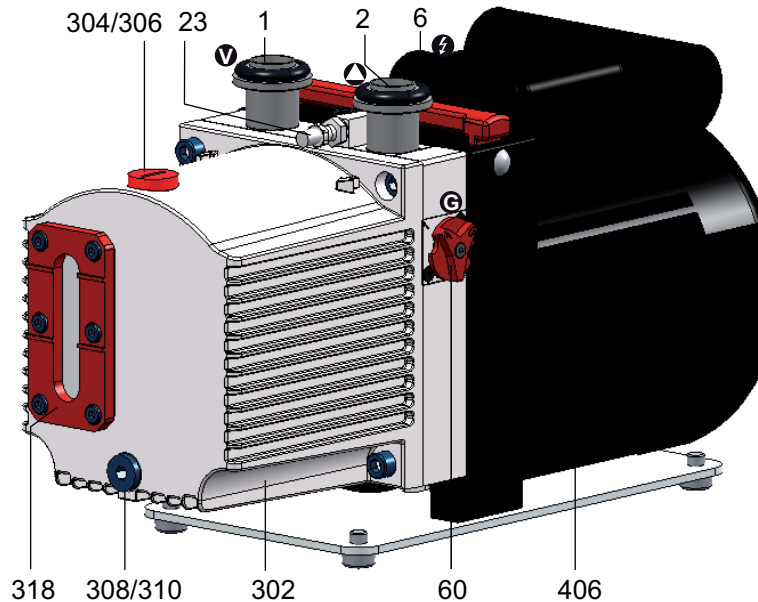

Fig. 3: DUO 3

1	Vacuum flange	60	Gas ballast valve	304	Operating fluid filler screw
2	Exhaust flange	302	Casing	306	O-ring
6	Connector IEC/C14	318	Sight glass	310	O-ring
23	Inlet port operating fluid return line	406	Motor		
		308	Operating fluid drain screw		

## 5 Installation

### 5.1 Set-up

#### Installation location

Observe the following requirements when setting up the pump:

- Consider the load-bearing capacity of the installation site.
- Maximum installation altitude 2000 m (above mean sea level)
- Permissible ambient temperature: +12 ... 40°C
- Maximum relative humidity 85%

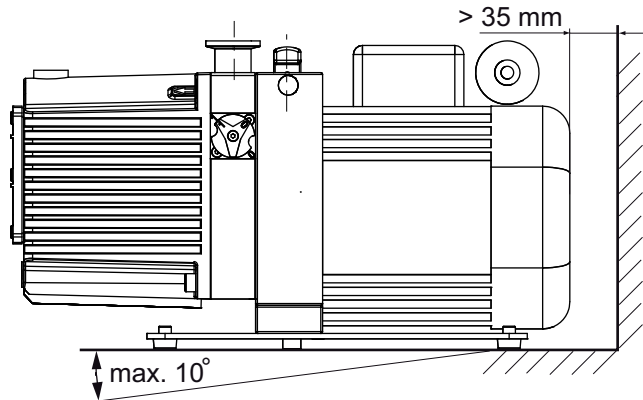

Fig. 4: Setting up the pump

- Fill up with operating fluid before operating the first time (see p. 10, chap. 5.2).
  - Amount and type according to rating plate
- Always place the pump on a firm, even surface.
- Where stationary installation is involved, anchor the pump on site; if necessary, exchange the base for one with mounting holes (on request).
- When installing the pump in a closed housing, ensure there is sufficient air circulation.
  - Sight glass and gas ballast valve must be visible and readily accessible.
  - Voltage and frequency information given on the motor rating plate must be visible.

## 5.2 Filling up the operating fluid

The type and amount of operating fluid should be visible on the pump's rating plate for every rotary vane pump.

The delivery consignment for the **standard pump** contains sufficient operating fluid for one filling. Pumps for special applications (e.g. for pumping corrosive gases) can be operated with other operating fluids. These must be defined in accordance with Pfeiffer Vacuum specifications before initial assembly and ordered separately.

### Permissible operating fluid

- P3 (standard operating fluid)
- Operating fluid for special applications on request



### NOTICE

#### Use approved operating fluids only!

The use of operating fluids that have not been approved by Pfeiffer Vacuum shall result in a limited warranty. In such cases, it is not possible to guarantee that product-specific performance data will be achieved.

- Prior consultation is required before using other application-specific operating fluids.

### Filling up the operating fluid

- Unscrew operating fluid filler screw 304.
- Fill up operating fluid;
  - correct filling level during operations: within the markings at the sight glass frame.

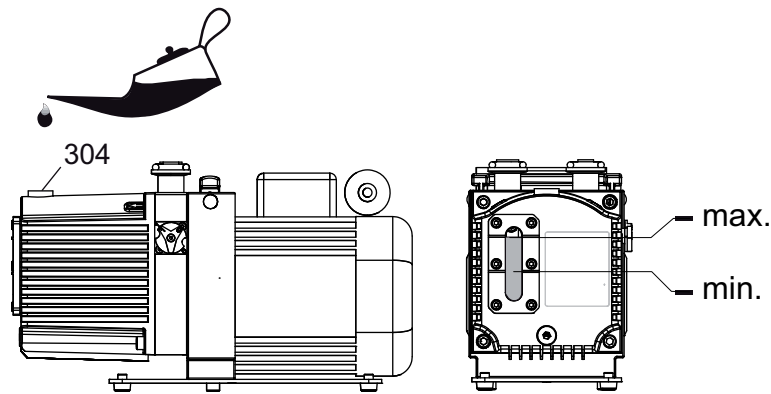

Fig. 5: Filling up the operating fluid

- Screw in operating fluid filler screw 304.
- Check operating fluid level only when the pump is warm and running; therefore
  - close vacuum flange and gas ballast valve.
  - Check operating fluid daily in non-stop operation, otherwise whenever the pump is switched on. Refilling is possible when the pump is in final vacuum operation.



#### WARNING

##### Toxic vapours!

Danger of poisoning when igniting and heating synthetic operating fluids (e.g. F4/F5) above 300°C.

- Observe the application instructions.
- Do not allow operating fluid to make contact with tobacco products; observe safety precautions when handling chemicals.

### 5.3 Connecting the vacuum side

- Remove locking cap from the vacuum flange;
  - pay attention to the cone strainer and the respective O-ring in the intake port.
- The connection between the pump and the vacuum chamber should be kept as short as possible.
  - Depending on the pump type, use metallic hoses or PVC hoses with flange connections.
  - Separators, filters etc. may be installed upstream to protect the pump (see accessories). However, please observe the loss of pumping capacity due to the conductivity of the accessories.

### 5.4 Connecting the exhaust side



#### CAUTION

##### High pressure in the exhaust line!

Danger of damage to the seals and danger of the pump bursting.

- Install the line without shut-off valves on the exhaust side.
- If there is danger of a build-up of excess pressure (> 1500 hPa abs.) in the lines, observe all official accident prevention safety regulations.
- If the exhaust gases are being extracted, the exhaust pressure must be at least 250 hPa greater than the pressure at the intake side.

- Remove the protective cap from the connection flange.
- Choose the cross-section of the exhaust line to be at least the size of the nominal connection diameter of the vacuum pump's exhaust connection.
- Piping to the pump must be suspended or supported.

- Physical forces from the piping system must not be allowed to act on vacuum pumps.
- Lay piping from the pump sloping downward so that no condensate can flow back into the pump; otherwise fit a condensate separator.
- If an air trap is created in the system, then a device for draining condensation water must be provided at the lowest point.



<b>WARNING</b>	
<b>Emission of toxic substances from the exhaust!</b>	
Danger of poisoning from emitted gases or vapours, which can be detrimental to health and/or can pollute the environment, depending on the particular application.	
→ Comply with the applicable regulations when working with toxic substances.	
→ Only officially approved filter systems may be used to separate and remove these substances.	

**Fitting the ONF and the oil return line (option)**

- Turn off the vacuum pump, vent to atmospheric pressure and allow to cool, if necessary.
- Remove the protective cap from the connection flange.
- Place ONF on the discharge side of the pump with flange pointing downwards and fit with clamping ring (accessories), pay attention to centering ring (accessories).

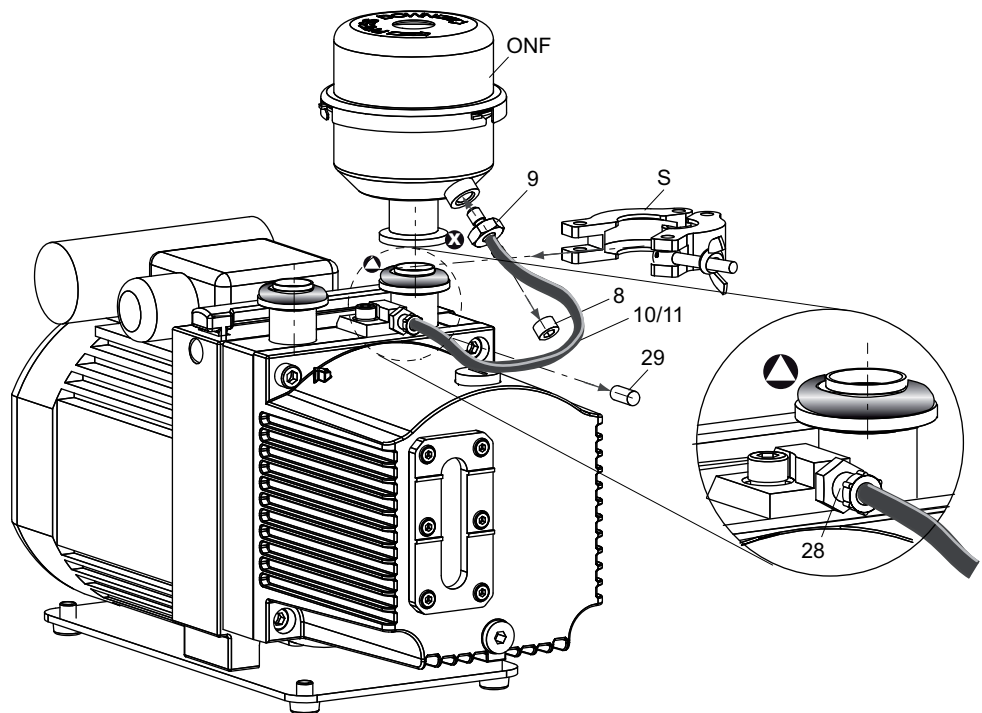

**Fig. 6: DUO 3 with operating fluid return line**

8	Locking screw	11	Spring (inside the hose)	29	Locking cap
9	Fitting	28	Fitting	S	Clamping ring
10	Operating fluid return hose				

**Note:** As the hexagon socket of the **locking screw** is not metric, a **special spanner (3/16")** (provided as part of the scope of supply) is required.

- Unscrew operating fluid drain screw 308.
- Drain off operating fluid if so and fill in the pump.
- Screw in fitting 9 in place of the locking screw; take care with seal ring.
- Loosen fitting 28 and remove cap 29.
- Insert spring 11 into hose 10 (anti-kink device).
- Fit operating fluid return hose 10 at both sides.

→ Tighten the union nuts of both screw fittings.

## 5.5 Connecting to the mains power supply



### NOTICE

#### Excess voltage!

Danger of destroying the motor.

- Power connections must comply with local regulations. Voltage and frequency information given on the motor rating plate must correspond to the mains voltage and frequency values.
- To protect the motor and supply cable in case of malfunction, mains fuse protection must be implemented.



### WARNING

#### Danger of injury from moving parts!

After power failure or motor shutdown due to overheating, the motor may restart automatically.

- Secure the motor so that it cannot be switched on while any work is being performed on the pump.
- If necessary, dismantle the pump from the installation for inspection.

### Single phase motors

The vacuum pumps are fitted with a built-in thermal protection switch. Depending on the type of pump, different motor versions with a mains cable are possible:

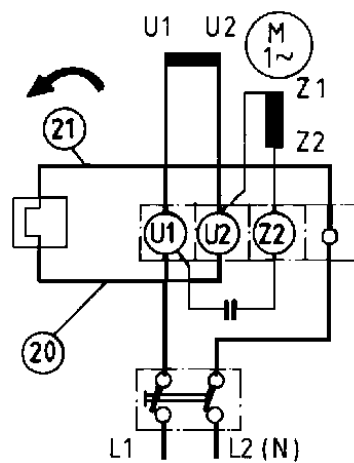
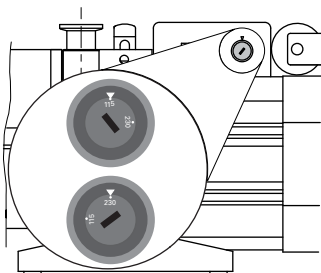

Fig. 7: Motor circuit diagram with switch

### Changing the voltage range

Only valid for pumps with reversible motor:

- The mains voltage must be determined on-site each time before the pump is installed or moved to a different location.
- Disconnect the pump from the power supply.
- Set the desired voltage range on the voltage selector switch using a suitable screwdriver.



Switch position:	"115"	"230"
Voltage ranges:	115 V ±10%, 50/60 Hz,	230 V ±10%, 50/60 Hz

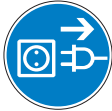

<b>NOTICE</b>	
<b>Overvoltage!</b>	
An incorrect voltage range setting can damage the motor.	
→ Disconnect the pump from the power supply.	
→ Only change the voltage range when the pump is disconnected from the power mains.	

**Fuse protection**

- To protect the motor in case of malfunction, carry out fuse protection in accordance with the regional regulations.
  - Select a fuse with slow characteristics.

Motor voltage [V]	Frequency [Hz]	Nominal current [A]	Recommended fuse, slow [A]
95 ... 105	50	3.2	6
100 ... 115	60	3.8	6
100 ... 105	50	3.2	6
110 ... 130	60	3.6	6
190 ... 210	50	1.6	4
200 ... 220	60	2	4
220 ... 240	50	1.4	4
220 ... 240	60	1.8	4
115/230	50	2.8/1.4	6/4
115/230	60	3.6/1.8	6/4

## 6 Operation

### 6.1 Before switching on the pump

- Check the operating fluid level in the sight glass.
- Compare the voltage and frequency information on the rating plate with the mains voltage and frequency values.
- Check that the exhaust connection allows free flow (max. permissible pressure 1.5 kPa absolute).
  - Activate the shut-off valves in such a way that they open before or at the same time as the pump is started.
- Protect the pump sufficiently from taking in contaminants by means of suitable precautions (e.g. dust filters); if necessary, check operating fluid regularly or replace at shorter intervals.

### 6.2 Switching on

The pump can be switched on in any pressure range between atmospheric and ultimate pressure.

No special precautions are necessary when pumping dry gases. In order to attain the lowest possible ultimate pressures, the gas ballast valve should be closed.



#### CAUTION

##### Hot surface!

Danger of burns if hot parts are touched. Depending on the operating and ambient conditions, the surface temperature of the pump may rise above 70 °C.

- In this case, use suitable finger guards.

### 6.3 Pumping condensable vapours

Should the process gases contain condensable gases present at high percentages, the rotary vane pump must be operated with gas ballast (i.e. with an open gas ballast valve).



#### NOTICE

##### Bad final vacuum and damage to the pump!

Danger of condensation and corrosion due to exceeding the water vapour compatibility during operation without gas ballast or in case of insufficient supply of flushing gas.

- Only pump vapours when the pump is warm and the gas ballast valve is open.
- When the process has been completed, allow the pump to continue running for about 30 minutes with the vacuum flange closed and the gas ballast open for operating fluid regeneration purposes.

#### Gas ballast valve, standard version

To avoid condensation in the pump when pumping condensable vapours, air is periodically fed into the working chamber at the beginning of the compression phase via the gas ballast valve 7.

The gas ballast valve is closed when turning to the right to position 0 and open when turning to the left to position 1. Intermediate settings are not possible.

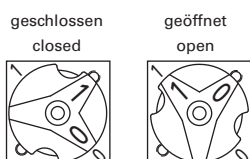
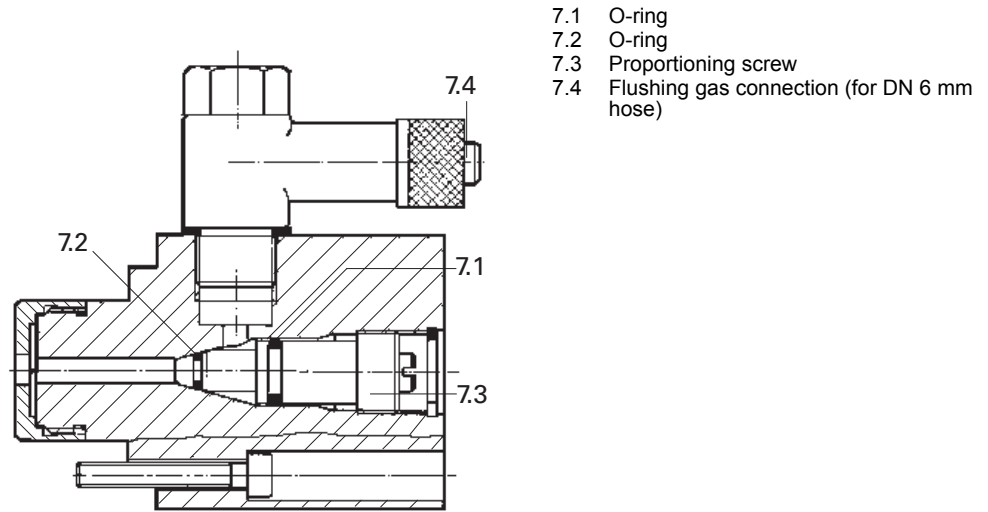

Fig. 8: Standard version of gas ballast valve

**Gas ballast valve,  
corrosive gas version**

If the pumping process requires the connection of flushing gas, the C version of the gas ballast valve with the flushing gas connection must be used.



**Fig. 9: Corrosive gas version of gas ballast valve**

- Connect flushing gas at the flushing gas connection 7.4.
- Set flushing gas pressure; maximum pressure 120 kPa (absolute).
  - Select the type and amount of flushing gas depending on the process; consult Pfeiffer Vacuum if necessary.
- Use the proportioning screw 7.3 to set the desired amount of gas.
  - Closed when fully turned to the right; open when fully turned to the left.

**Gas ballast valve with  
solenoid valve**

To control the flow of the flushing gas externally, an electromagnetic valve can also be used as an alternative to the versions described above. The valve makes it easier to operate the gas ballast and allows clean air or other gas to be let in in a process-controlled manner.



**NOTICE**

**Flushing gas pressure higher than allowed endangers the operational reliability of the pump.**

The power input of the pump, the temperature and the ejection of operating fluid will increase.

- Observe the maximum permissible flushing gas pressure of 150 kPa (absolute).
- Set the amount of flushing gas on site; dosing is not possible when using a solenoid valve!



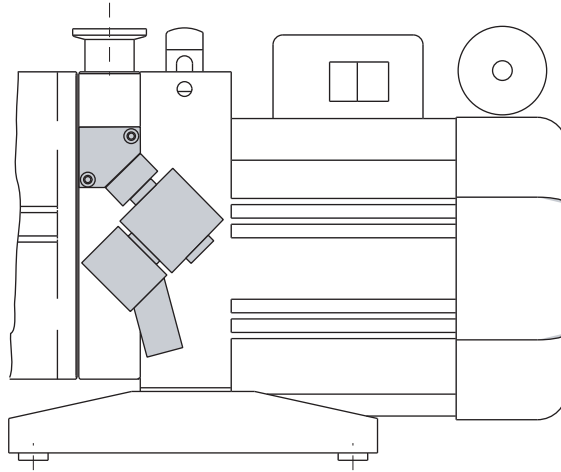

**Fig. 10: Assembling the solenoid valve at the gas ballast inlet**

**Performance data of the solenoid valve**

2/2 way valve	closed when disconnected
Supply voltage	24 VDC, +/- 10 %
Power input	4 W
Socket	Type 2506
Threaded connection of flushing gas	1/8" inside
Flushing gas pressure	max. 150 kPa (absolute)
Amount of flushing gas	max. 180 l/h

## 6.4 Switching off the pump

The pump can be switched off in any pressure range.

Rotary vane pumps have an integrated safety valve on the intake side. If the differential pressure between the exhaust side and the intake side is  $\geq 250$  hPa, then the valve closes automatically and vents the pump when the pump is switched off.

→ Switch the pump off at the mains switch or disconnect from the mains in a secure manner.

### Venting the vacuum chamber



#### NOTICE

##### **Danger of backflow of operating fluid into the intake line!**

Contamination of the connected vacuum system!

- Vent the vacuum chamber within 30 s, regardless of the chamber size.
- For a longer venting process, use an additional shut-off valve and shut off the intake line after switching off the pump.

### Maintaining the vacuum in the chamber



#### NOTICE

##### **Danger of backflow of operating fluid into the intake line!**

Contamination of the connected vacuum system!

- Because the safety valve of the pump is not suitable for longer-term sealing, install an additional shut-off valve in the intake line.
- Shut off the intake line immediately after switching off the pump.

## 7 Maintenance

### 7.1 Precautions



#### WARNING

##### **Danger of injury from moving parts!**

After power failure or motor shutdown due to overheating, the motor may restart automatically.

- Secure the motor so that it cannot be switched on while any work is being performed on the pump.
- If necessary, dismantle the pump from the installation for inspection.



#### WARNING

##### **Pump parts may be contaminated from pumped media!**

Danger of poisoning due to contact with harmful substances.

- Decontaminate the pump before carrying out any maintenance work.
- In the event of contamination, take suitable safety precautions to prevent your health from being harmed by any dangerous substances.

- Turn off the vacuum pump, vent to atmospheric pressure and allow to cool, if necessary.
- Disconnect the drive motor from the mains and secure it so that it cannot be switched on.
- Only dismantle the pump as far as necessary in order to repair defects.
- Dispose of used operating fluid in compliance with local regulations.
- When using synthetic operating fluids or working with toxic substances or substances contaminated with corrosive gases, the relevant instructions governing their use must be observed.
- Use only alcohol or similar agents for cleaning pump parts.

**Checklist for inspection, maintenance and overhaul**

Certain repair and overhaul work should only be performed by Pfeiffer Vacuum Service (PV). Pfeiffer Vacuum will be released from all warranty and liability claims if the required intervals for inspection, maintenance, or overhaul are exceeded or inspection, maintenance, repair or overhaul procedures are not performed properly. This also applies if replacement parts other than Pfeiffer Vacuum OEM replacement parts are used.

Activity	daily	as required; at least annually	as required; at least every 2 years	as required; at least every 4 years
Check operating fluid level	X			
Visual inspection (leak-tightness/oil leaks)	X			
Check filter insert of external oil mist filter (if existent)	X			
Change filter insert of external oil mist filter (if existent)		X		
Change operating fluid		X		
Change oil filter (if existent)		X		
Cleaning the pump and renew the seals		X		
Clean gas ballast valve and silencer		X		
Clean the motor fan cap		X		
Replace radial shaft seal			X (PV)	
Clean or change vacuum safety valve			X (PV)	
Clean or change exhaust valves			X (PV)	
Change vanes				X (PV)
Check or change coupling				X (PV)

Depending on the process, the required replacement intervals for the operating fluid and the intervals for inspection, maintenance and overhaul may be shorter than the guide values specified in the table. Consult Pfeiffer Vacuum Service, if necessary.

## 7.2 Changing the operating fluid

The changing interval for the operating fluid depends on the pump applications, but should be carried out once a year.



**Depending on the applications, Pfeiffer Vacuum recommends determining the exact service life of the operating fluid during the first year of operation.**

The replacement interval may vary from the guide value specified by Pfeiffer Vacuum depending on the thermal and chemical loads, and the accumulation of suspended particles and condensation in the operating fluid.

- The level of deterioration of operating fluid P3 can be determined for clean processes with the colour scale (in accordance with DIN 51578); supplementary sheet PK 0219 BN on request or download it from the Internet.
- Suck off operating fluid from the pump through the operating fluid filler opening.
- Fill the specimen in a test tube or some similar vessel and test by holding against the light.
- Where discolouration is red brown (equivalent to 5 on the scale) change operating fluid.
- Switch off the pump.
- Unscrew operating fluid filler screw 304.
- Unscrew operating fluid drain screw 308.

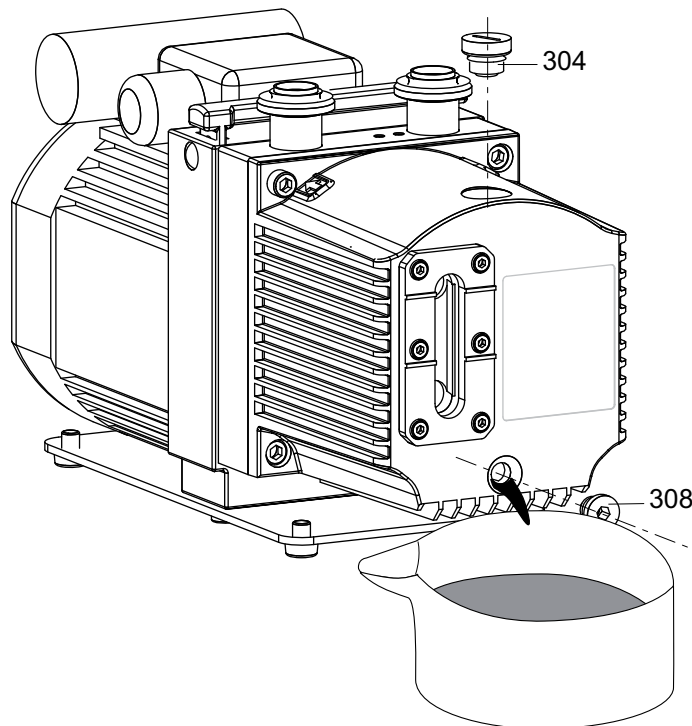

Fig. 11: Draining the operating fluid



### WARNING

**Hot operating fluid!**

Danger of burns when draining due to contact with skin.

- Wear suitable protective clothing.
- Use a suitable collecting vessel.



### WARNING

#### Operating fluid may contain toxic substances from the pumped media!

Danger of poisoning from the emission of harmful substances from the operating fluid.

- Wear suitable protective clothing and respirators.
- Dispose of operating fluid according to the local regulations

- Screw in operating fluid drain screw 308; pay attention to O-ring.
- Screw in operating fluid filler screw 304.
- Allow pump to run for a maximum of 5 seconds with the vacuum flange open.
- Drain off remaining operating fluid.
  - In case of serious contamination, the operating fluid will have to be changed several times (flushing):

## Flushing

- Fill up with operating fluid to the middle of the sight glass.
- Operate the pump with the gas ballast open until the pump has warmed up.
- Drain the operating fluid again and check for contamination, flush again if necessary.
- Screw the operating fluid drain screw back in.
- Fill up with operating fluid and check the filling level (*see p. 10, chap. 5.2*).



#### Request safety data sheets for operating fluids and lubricants

from Pfeiffer Vacuum or download them from the Internet.

- Dispose of operating fluid according to the local regulations.

## 8 Decommissioning

### 8.1 Shutting down for longer periods

Before shutting down the pump, observe the following procedure and adequately protect the pump system against corrosion:

- Switch off pump.
- Change operating fluid.
- Start the pump and allow the pump to warm up.
- Switch off the pump.
- Fill up the pump with new operating fluid to the top edge of the sight glass.
- Close vacuum flange and exhaust flange with locking caps.
- Store the pump in a cool, dry place; preferably at temperatures between -10 °C and +40 °C.
  - For a longer period of storage, seal the pump in a PE bag with drying agents enclosed.
  - For a period of storage longer than two years, it is recommended to change the operating fluid before using the pump.
- Do not store pump in the vicinity of machines, lanes, etc., because strong vibrations can damage the rotor bearings.

### 8.2 Re-starting



#### Emission of operating fluid!

Danger of the operating fluid being emitted at the exhaust flange if overfilled.

- Drain the operating fluid to the normal level before restarting the pump.



#### NOTICE

#### Re-starting

The serviceability of the operating fluid without operation is a maximum of 2 years. Before restarting after a shut-down of **2 years or longer**, carry out the following work.

- Replace the operating fluid.
- Replace the radial shaft sealing rings and further elastomer parts.
- Replace bearings at pumps with anti-friction bearings.
- Follow the maintenance instructions and inform Pfeiffer Vacuum.

### 8.3 Disposal

Products or parts thereof (mechanical and electrical components, operating fluids, etc.) may cause environmental burden.

- Safely dispose of the materials according to the locally applicable regulations.

## 9 Malfunctions

Please note the following instructions should the pump malfunction:



### CAUTION

#### Hot surface!

Danger of burns if hot parts are touched. The surface temperature of the pump may rise above 105 °C in case of malfunction.

→ Carry out work on the pump only after it has cooled to a safe temperature.



### NOTICE

#### Motor overload!

Depending on the malfunction (e.g. blocking during cold start), the motor may not be sufficiently protected by the built-in thermal protection switch from damage through overheating.

→ Implement an additional network safety device.

### 9.1 Rectifying malfunctions

Problem	Possible causes	Remedy
Pump will not start up	No mains voltage or voltage does not correspond to the motor data	Check mains voltage and mains fuse protection; check motor switch
	Pump temperature too low	Warm up pump to > 12°C
	Thermal protection switch has responded	Detect and fix cause of overheating; allow pump to cool off if necessary.
	Pump system dirty	Clean pump; contact Pfeiffer Vacuum Service if necessary.
	Pump system damaged	Clean and overhaul pump; contact Pfeiffer Vacuum Service if necessary.
	Motor defective	Replace motor
Pump switches off after a while after being started	Thermal protection switch of the motor has responded	Detect and fix cause of overheating; allow motor to cool off if necessary.
	Mains fuse protection triggered due to overload (e.g. cold start)	Warm up pump
	Exhaust pressure too high	Check opening of exhaust line and exhaust accessories
Pump does not attain ultimate pressure	Measurement reading is false	Check gauge, check ultimate pressure without installation connected.
	Pump or connected accessories are dirty	Clean pump and check components for contamination.
	Operating fluid dirty	Operate pump for a longer period with gas ballast valve open or change operating fluid
	Leak in system	Repair leak
	Operating fluid filling level too low	Top off operating fluid
	Pump damaged	Contact Pfeiffer Vacuum Service.
Pumping speed of pump too low	Intake line not well-dimensioned	Keep connections as short as possible and ensure that cross-sections are sufficiently dimensioned
	Exhaust pressure too high	Check opening of exhaust line and exhaust accessories
Loss of operating fluid	Swivel gasket leaky	Check tightness; replace gasket if necessary
	Radial shaft seal ring leaky	Replace seal ring and check bushing
	Operational loss of operating fluid	If necessary, install oil mist filter and oil return unit
Unusual operating noises	Silencer dirty	Clean or replace the silencer.
	Damage to the pump system	Clean and overhaul pump; contact Pfeiffer Vacuum Service if necessary.
	Motor bearing defective	Replace motor; contact Pfeiffer Vacuum Service if necessary



**NOTICE**

**Service work should be carried out by qualified personal only!**

Pfeiffer Vacuum is not liable for any damage to the pump resulting from work carried out improperly.

- Take advantage of our service training programs; additional information at [www.pfeiffer-vacuum.com](http://www.pfeiffer-vacuum.com).
- Please state all the information on the pump rating plate when ordering spare parts.



## 10 Service

### **Pfeiffer Vacuum offers first-class service!**

- Maintenance/repairs on site by Pfeiffer Vacuum field service
- Maintenance/repairs in a nearby service center or service point
- Fast replacement with exchange products in mint condition
- Advice on the most cost-efficient and quickest solution

Detailed information and addresses at: [www.pfeiffer-vacuum.com](http://www.pfeiffer-vacuum.com) (Service).

### **Maintenance and repairs in Pfeiffer Vacuum ServiceCenter**

The following steps are necessary to ensure a fast, smooth servicing process:

- Download the forms "Service Request" and "Declaration on Contamination".<sup>1)</sup>
- Fill out the "Service Request" form and send it by fax or e-mail to your Pfeiffer Vacuum service address.
- Include the confirmation on the service request from Pfeiffer Vacuum with your shipment.
- Fill in the contamination declaration and enclose it in the shipment (required!).
- Dismantle all accessories.
- Drain operating fluid/lubricant.
- Drain cooling medium, if used.
- Send the pump or unit in its original packaging if possible.

### **Sending of contaminated pumps or devices**

No units will be accepted if they are contaminated with micro-biological, explosive or radioactive substances. "Hazardous substances" are substances and compounds in accordance with the hazardous goods directive (current version). If pumps are contaminated or the declaration on contamination is missing, Pfeiffer Vacuum performs decontamination at the shipper's expense.

- Neutralise the pump by flushing it with nitrogen or dry air.
- Close all openings airtight.
- Seal the pump or unit in suitable protective film.
- Return the pump/unit only in a suitable and sturdy transport container and send it in while following applicable transport conditions.

### **Service orders**

All service orders are carried out exclusively according to our repair conditions for vacuum units and components.

<sup>1)</sup> Forms under [www.pfeiffer-vacuum.com](http://www.pfeiffer-vacuum.com)

# 11 Spare parts

## 11.1 Spare parts packages

The spare parts packages listed here are only applicable for standard models.

Please state all information on the rating plate when ordering spare parts. Other spare parts than those described in this manual must not be used without the agreement of Pfeiffer Vacuum.

### Set of seals

The set of seals contains all seals including all O-rings of the assembly groups and the subassemblies.

### Maintenance kit

The pack contains the O-rings of the operating fluid filler and drain screw for changing the operating fluid. Also the radial shaft seal ring(s) and the O-ring for the casing after cleaning the operating fluid sump is included.

### Set of vanes

The pack contains the vanes of the pump stages and the vane springs.

### Overhaul kit

The pack contains all wearing parts of the pump to replace the following parts after dismantling the whole pump:

- Set of seals
- Wearing parts of the pumping system
- Wearing parts of the vacuum safety valve
- Wearing parts of the gas ballast valve.

### Set of vacuum safety valve

The pack contains the wearing parts of the vacuum safety valve. Also the O-rings between the valve housing and the pumping system and the O-ring of the casing are included.

### Set of discharge valves

The pack contains the wearing parts of the discharge valves. Also the wearing parts of the exhaust valve and the O-ring of the casing are included.

### Coupling kit

The pack contains the coupling halves, the can and the radial shaft seal rings.

Spare parts package	No.	Parts according to the exploded view on the following page
Set of seals	PK E00 030 -T	25, 26, 27, 29, 40, 42, 63, 92, 204, 206, 208, 306, 310, 312, 314, 412.
Set of vanes	PK E08 030 -T	118, 120, 122.
Maintenance kit	PK E01 040 -T	42, 102, 310, 312, 412.
Overhaul kit	PK E02 040 -T	Set of seals, 44, 74, 118, 120, 122, 124, 212, 214, 216, 218, 316.
Pumping system, DUO 1.6	PK E03 018 -U	102, 104, 106, 110, 112, 114, 118, 120, 122, 124, 126, 128, 130, 132, 222.
Pumping system, DUO 3	PK E03 019 -U	102, 104, 106, 110, 112, 114, 118, 120, 122, 124, 126, 128, 130, 132, 222.
Set of vacuum safety valve	PK E04 011 -T	204, 206, 208, 212, 214, 216, 218, 312.
Set of discharge valves	PK E05 015 -T	124, 204, 206, 208, 312.
Gas ballast valve	PK E09 000 -T	60.
Coupling kit	PK E06 008 -T	42, 44, 412.

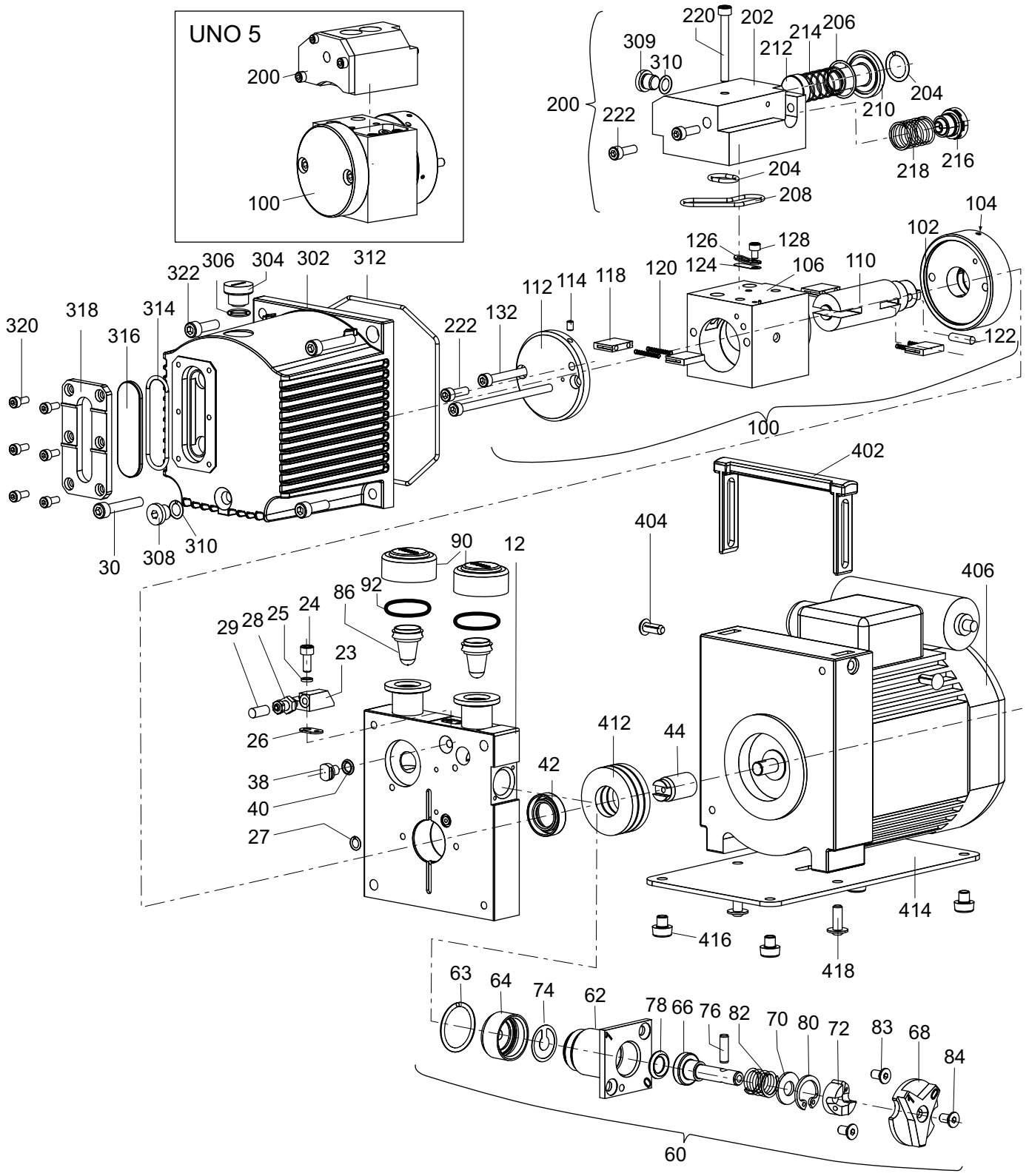

Fig. 12: Exploded view DUO 3

## Spare parts

---

12	Support stand	83	Countersunk screw	210	Valve seat
23	Connection operating fluid return line	84	Countersunk screw	212	Valve plate
24	Cylinder head screw	86	Centering ring with cone strainer	214	Compression spring
25	Sealing ring	90	Locking cap	216	Hydraulic valve
26	Flat seal	92	O-ring	222	Cylinder head screw
27	O-ring	100	Pumping system, complete	218	Compression spring
28	Fitting	102	Support plate	220	Cylinder head screw
29	Cap	104	Nozzle	302	Casing
30	Cylinder head screw	106	Cylinder	304	Operating fluid filler screw
38	Silencer	110	Rotor	306	O-ring
40	O-ring	112	Bearing cover	308	Operating fluid drain screw
42	Radial shaft seal ring	114	Stud screw	309	Locking screw
44	Coupling, motor side	116	Cylinder head screw	310	O-ring
60	Gas ballast valve, complete	118	Vane	312	O-ring
62	Flange housing	120	Compression spring	314	O-ring
63	O-ring	122	Hydraulic vane	316	Sight glass
64	Screw cap	124	Valve flap	318	Sight glass frame
66	Tappet	126	Valve trap	320	Cylinder head screw
68	Knob	128	Cylinder head screw	322	Cylinder head screw
70	Washer	130	Dowel pin	402	Handle
72	Camp plate	132	Cylinder head screw	404	Groove pin
74	Valve tongue	200	Vacuum safety valve, complete	406	Motor
76	Cylinder Pin	202	Valve housing	412	Felt ring
78	O-ring	204	O-ring	414	Base plate
80	Circlip	206	O-ring	416	Rubber foot
82	Compression spring	208	O-ring	418	Lens head screw

## 12 Accessories

Designation	DUO 3
SAS 16, DN 16 ISO-KF, polyester filter	PK Z60 506
KAS 16, condensate separator for pumping speeds from 1.25 to 5 m <sup>3</sup> /h	PK Z10 003
ONF 1-9, oil mist filter for pumping speeds of up to 9 m <sup>3</sup> /h	PK Z40 001
Oil return unit from ONF 1-9 to DUO 1.6 / DUO 3	PK 005 986 -T
ONF 16, oil mist filter for pumping speeds of up to 1.25-5 m <sup>3</sup> /h	PK Z40 003
Oil return unit from ONF 16 to DUO 1.6, 3, 6, 11	PK 006 080 -T
ZFO 16, zeolite trap	PK Z70 003
Operations monitoring unit 3 - operating fluid level, operating fluid temperature, exhaust pressure	PK 196 141 -T
Operations monitoring unit 2 - operating fluid level, operating fluid temperature	PK196 142 -T
Operations monitoring unit 1 - operating fluid level	PK 196 157 -T
Mains cable 230 V with safety plug CEE 7, right angle IEC 320/C13 socket, 2 m	PK 050 109
Mains cable 115 V with NEMA-plug, right angle IEC 320/C13 socket, 2 m	PK 050 110

## 13 Technical data and dimensions

### 13.1 General

Conversion table: pressure units

	mbar	bar	Pa	hPa	kPa	Torr mm Hg
mbar	1	$1 \cdot 10^{-3}$	100	1	0.1	0.75
bar	$1 \cdot 10^3$	1	$1 \cdot 10^5$	1000	100	750
Pa	0.01	$1 \cdot 10^{-5}$	1	0.01	$1 \cdot 10^{-3}$	$7.5 \cdot 10^{-3}$
hPa	1	$1 \cdot 10^{-3}$	100	1	0.1	0.75
kPa	10	0.01	1000	10	1	7.5
Torr mm Hg	1.332	$1.332 \cdot 10^{-3}$	133.32	1.3332	0.1332	1

$1 \text{ Pa} = 1 \text{ N/m}^2$

Conversion table: gas throughput units

	mbar l/s	Pa m <sup>3</sup> /s	sccm	Torr l/s	atm cm <sup>3</sup> /s
mbar l/s	1	0.1	59.2	0.75	0.987
Pa m <sup>3</sup> /s	10	1	592	7.5	9.87
sccm	$1.69 \cdot 10^{-2}$	$1.69 \cdot 10^{-2}$	1	$1.27 \cdot 10^{-2}$	$1.67 \cdot 10^{-2}$
Torr l/s	1.33	1.33	78.9	1	1.32
atm cm <sup>3</sup> /s	1.01	0.101	59.8	0.76	1

### 13.2 Technical data

Parameter	DUO 3
Flange (in)	DN 16 ISO-KF
Flange (out)	DN 16 ISO-KF
Pumping speed at 50 Hz	2.5 m <sup>3</sup> /h
Pumping speed at 60 Hz	2.9 m <sup>3</sup> /h
Ultimate pressure with gas ballast	3 · 10 <sup>-3</sup> hPa
Ultimate pressure without gas ballast	3 · 10 <sup>-3</sup> hPa
Exhaust pressure, min.	250 hPa
Exhaust pressure, max.	1500 hPa
Rotation speed at 50 Hz	3000 rpm
Rotation speed at 60 Hz	3600 rpm
Leak rate safety valve	≤ 1 · 10 <sup>-4</sup> hPa l/s
Emission sound pressure level without gas ballast at 50 Hz	≤ 53 dB (A)
Ambient temperature	12-40 °C
Protection category	IP 55
Rated power 50 Hz	0.15 kW
Rated power 60 Hz	0.18 kW
Mains requirement: voltage 50 Hz	220-240 V
Mains requirement: voltage 60 Hz	220-240 V
Switch	Yes
Mains cable	No
Shipping and storage temperature	-25-+55 °C
Operating fluid	P3
Operating fluid filling	0.4 l
Weight	10.5 kg
Cooling method, standard	Air
Temperature: Operating	80 °C

Ultimate pressure according to PNEUROP

### 13.3 Dimensions

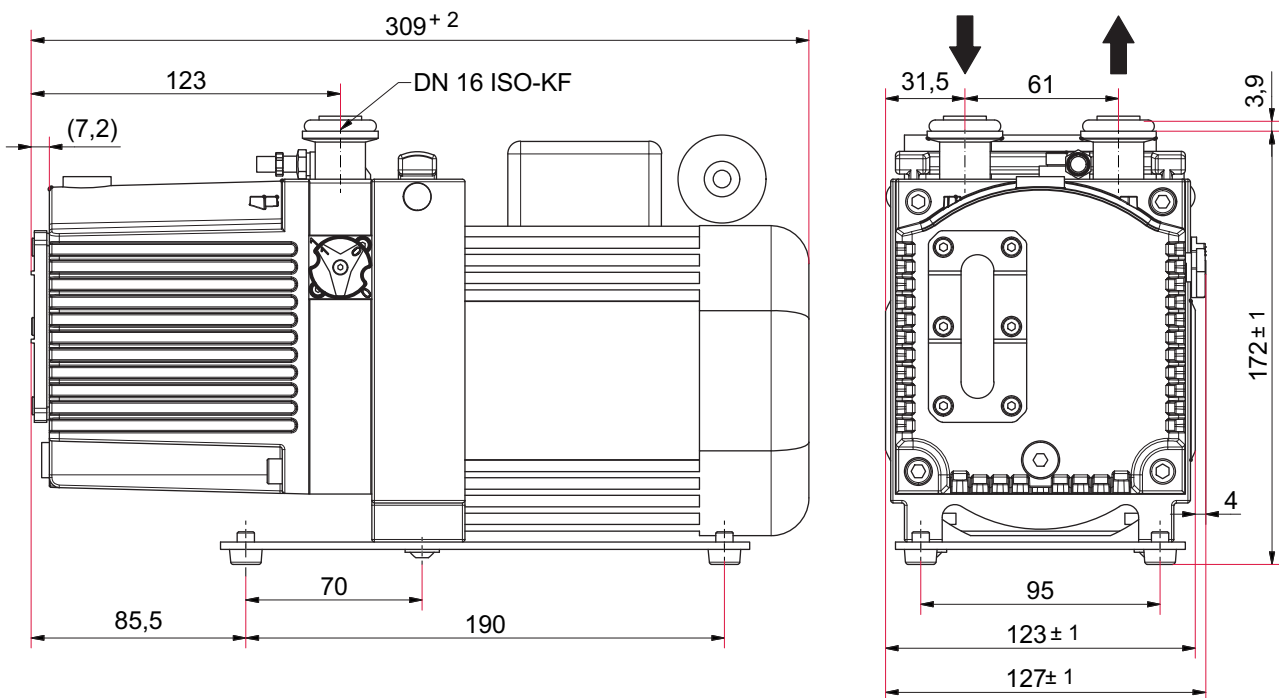

Fig. 13: Motor version: 220-240, 50/60 Hz



# Declaration of conformity

according to the EC directive:

- **Machinery 2006/42/EC (Annex II, no. 1 A)**

We hereby declare that the product cited below satisfies all relevant provisions of EC directive "Machinery" **2006/42/EC**.

In addition, the product cited below satisfies all relevant provisions of EC directive "Electromagnetic Compatibility" **2004/108/EC**.

The agent responsible for compiling the technical documentation is Mr. Sebastian Oberbeck, Pfeiffer Vacuum GmbH, Berliner Straße 43, 35614 Asslar.

**DuoLine**

**DUO 3**

Guidelines, harmonised standards and national standards and specifications which have been applied:

DIN EN ISO 12100 : 2011-03	DIN EN 61010 : 2002	DIN EN 61000-6-3 : 2007
DIN EN 1012-2 : 1996	DIN EN 61000-6-1 : 2007	DIN EN 61000-6-4 : 2007
DIN EN ISO 13857 : 2008	DIN EN 61000-6-2 : 2006	

Signatures:

Pfeiffer Vacuum GmbH  
Berliner Straße 43  
35614 Asslar  
Germany

---

(M.Bender)  
Managing Director

(Dr. M. Wiemer)  
Managing Director

CE/2012

**Vacuum solutions  
from a single source**

Pfeiffer Vacuum stands for innovative and custom vacuum solutions worldwide, technological perfection, competent advice and reliable service.

**Complete range  
of products**

From a single component to complex systems: We are the only supplier of vacuum technology that provides a complete product portfolio.

**Competence in  
theory and practice**

Benefit from our know-how and our portfolio of training opportunities! We can support you with your plant layout and provide first-class on-site-service worldwide.

**Are you looking for a  
perfect vacuum solution?  
Please contact us**

**Pfeiffer Vacuum GmbH**  
Headquarters • Germany  
T +49 6441 802-0  
info@pfeiffer-vacuum.de